

ThermoFLUX

ThermoFLUX d.o.o., Bage br. 3, 70101 Jajce, Bosnia and Hercegovina, Tel/Fax: 387 30-657-100
www.thermoflux.ba tinfo@thermoflux.ba

PELLET STOVE

INTERIO



USER AND MAINTENANCE MANUAL



EC-DECLARATION OF CONFORMITY

In accordance with ISO/IEC Guide 22 and EN 45014



We.....: **ThermoFLUX d.o.o.**
Bage 3
70101 Jajce
Bosna i Hercegovina

We declare with sole responsibility that the product:

Name / Mark.....: Pellet stoves

Type / Model.....: INTERIO 14; INTERIO 20

To which this declaration relates, in accordance with the following normative documents:

EC-Directives : (EU) 305/2011 – Construction Products Regulations
MD 2006/42/EC – Directive on Machinery
LVD 2006/95/EC – Low Voltage Legislation
EMC 2004/108/EC – Electromagnetic compatibility

Applied harmonized standards: EN 14785:2006; EN ISO 12100:2010; EN 287-1: 2011

Other specified standards and specifications: EN 55014-1:2006/A2:2011; EN 55014-2:1997/A2:2008; EN 6100-3-2:2006/A2:2009; EN 61000-3-3:2008; EN 10201:2004; EN ISO 7000:2004

Applied procedures for assessing compliance: Modul 3
Limit values for emissions of combustion products (class): 5
Certificates that are issued: Report on type testing no.: PL-12112/1-P; PL-12112/2-P

Accredited body: TU Wien; Prüflabor für Feuerungsanlagen - Inst. f.
Verfahrenstechnik, Umwelttechnik und Techn.
Biowissenschaften Getreidemarkt 9 | 166; A-1060 Wien

We hereby declare that the above named product concept and method of preparation, in accordance with safety and security standards that comply with the above directives and standards.

In doing all operating conditions and terms of use in accordance with the attached instruction manual and technical documentation.

When only one change to the product which is not in agreement with us, this declaration loses its importance.

Last name, first name and title of signatory

Jajce 01.02.2017.

Place and date



General Manager, Tomislav Ladan

Signature, seal

Dear users,

Congratulations on choosing a boiler from ThermoFLUX d.o.o..

Please note that all persons handling this pellet stove inspect and observe the operating instructions and safety instructions. Always keep the instructions in a place near the stove.

Due to constant improvement and development of our products some pictures or illustrations in this guide may vary.

IMPORTANT INFORMATION:

The first commissioning and training of the user must be done by a service authorized by ThermoFLUX d.o.o. or the importer, otherwise the guarantee will not be valid.

Content:

| | | |
|----------|--|-----------|
| 1 | NOTES ON THE MANUAL | 6 |
| 1.1 | Easy and safe operation | 6 |
| 1.2 | Technical changes | 6 |
| 1.3 | Copyright | 6 |
| 1.4 | Security measures | 6 |
| 1.5 | Basic principles and operation | 7 |
| 1.6 | Warning signs | 8 |
| 1.7 | Other warnings | 9 |
| 1.7.1 | System overheating | 10 |
| 1.7.2 | Smoke | 10 |
| 1.7.3 | Fire in the room | 10 |
| 2 | GENERAL OVERVIEW | 11 |
| 2.1 | GSM modem | 11 |
| 2.2 | Wi-Fi module | 12 |
| 2.3 | Technical data | 12 |
| 3 | SAFETY INSTRUCTIONS | 15 |
| 3.1 | Proper use | 15 |
| 3.1.1 | Basic principles | 15 |
| 3.1.2 | Handling with the stove | 15 |
| 3.1.3 | Use of the stove | 15 |
| 3.1.4 | Changes on the stove | 15 |
| 3.2 | Pellets that can be used in boilers | 16 |
| 3.2.1 | What is pellet | 16 |
| 3.2.2 | Recommended wood pellets and standars | 16 |
| 3.2.3 | Unallowed fuels | 16 |
| 3.3 | Obligatory information | 17 |
| 3.4 | Local standards | 17 |
| 3.5 | Safety instructions for the heating room | 17 |
| 3.6 | Fresh air supply | 18 |
| 3.7 | Boiler safety devices | 18 |
| 4 | Installation | 19 |
| 4.1 | Installation conditions | 19 |
| 4.1.1 | Switch off main power supply | 20 |
| 4.1.2 | Check mechanical connections | 20 |
| 4.1.3 | Check hydraulic connections | 20 |
| 4.2 | Chimney and flue gas pipes | 20 |

| | | |
|-----------|--|-----------|
| 5 | Connection | 23 |
| 5.1 | Hydraulic schemes for connection | 23 |
| 5.2 | Electric scheme connection | 24 |
| 5.2.1 | Power supply | 25 |
| 5.2.2 | Room thermostat | 25 |
| 6 | Function of stove | 26 |
| 6.1 | Overview of the controls and display and their basic functions..... | 26 |
| 6.2 | Principle of stove operation | 28 |
| 6.3 | Schematic representation of the menu control..... | 29 |
| 6.3.1 | Clock adjustments | 31 |
| 6.3.2 | Adjustments of the programmed on and off mode | 32 |
| 6.3.4 | LANGUAGE OPTIONS | 34 |
| 6.3.5 | STAND BY mode..... | 34 |
| 6.3.5.1 | <i>STAND BY mode with installed sensor for water temperature.....</i> | <i>34</i> |
| 6.3.5.2 | <i>STAND BY mode with room thermostat connected.....</i> | <i>35</i> |
| 6.3.6 | Option Buzzer | 35 |
| 6.3.7 | Filling of spiral dispenser | 36 |
| 6.3.8 | STATE OF THE STOVE | 36 |
| 6.3.9 | Technical settings..... | 36 |
| 6.3.10 | FUEL TYPE..... | 36 |
| 7 | Ignition and shutting down of stove..... | 37 |
| 7.1 | Ignition | 37 |
| 7.2 | Shutting down of stove..... | 38 |
| 7.3 | Stove power adjustments | 38 |
| 7.4 | Adjustment of water temperature in stove | 39 |
| 7.5 | Modulation..... | 40 |
| 7.6 | Cleaning of FIRE-POT | 40 |
| 8 | Cleaning and maintenance | 41 |
| 8.1 | Daily cleaning..... | 41 |
| 8.2 | Weekly cleaning | 41 |
| 8.3 | Cleaning the tube heat exchanger..... | 42 |
| 9 | Alarms..... | 45 |
| 10 | Instruction about safety removal and proper disposal of stove | 47 |
| 10.1 | Disposal | 47 |
| 11 | Guarantee..... | 48 |
| 11.1 | Guarantee period..... | 48 |
| 11.2 | Guarantee terms | 48 |
| 11.3 | Exemption from the guarantee | 48 |

1 NOTES ON THE MANUAL

1.1 Easy and safe operation

This manual is an integral part of the stove and contains important information for proper and safe operation of the Interio pellet stove. Following the instructions in this manual, the stove will work properly and you will avoid the danger, the costs of repairing failures, and at the same time the lifetime of the stove continues.

1.2 Technical changes

ThermoFLUX constantly develops and improves its stoves. The information in this manual is accurate at the time it is printed.

All the details in this guide on standards and regulations should be checked and compared before using the stove that is installed.

We reserve the right to make any changes that may result in deviation from the technical details and illustrations shown in this manual.

1.3 Copyright

It is forbidden to copy and download content from this manual!

Required written permission by ThermoFLUX d.o.o. before any copying, storage in data transmission systems electronically, mechanically or in any other way. As well as copying and publication of parts or the entire instruction.

1.4 Security measures

The pellet stove is designed and manufactured in accordance with the Safety regulations.

EU-Directives:

(EU) 305/2011
MD 2006/42/EG
LVD 2006/95/EG
EMV 2004/108/EG











The stoves Fulfill other specified standards and specifications: EN 55014-1: 2006 / A2: 2011; EN 55014-2: 1997 / A2: 2008; EN 6100-3-2: 2006 / A2: 2009; EN 61000-3-3: 2008; EN 10201: 2004; EN ISO 7000: 2004.

Improper use of the stove can result in bodily injury, leading ultimately to the death of users and/or others as well as damage to the stove itself or other property.

1.5 Basic principles and operation

The Interio pellet stove is a special heater intended exclusively for domestic use and intended only for burning wood pellets of 6 mm diameter and 30 mm length. During operation, the integrated heat exchanger produces hot water which is delivered to a central heating system. The integrated pump only switches on when the preset water temperature in the system (50°C) is reached. For normal operation, it is only necessary to start the stove and select the desired power value or temperature. By installing the room thermostat, it is possible to automatically ignite and control the stove. The pellets automatically fall into the burn pot and then are ignited with an electric heating cartridge. Depending on the set value of the power, the pellet conveyor automatically adds the required amount of pellets. The required air supply for combustion into the combustion chamber is controlled. The resulting heat energy in the combustion chamber is supplied to the central heating. At the end of the combustion chamber there is an exhaust fan, which releases the flue gases created in the chimney. Every day it is recommended to clean the ashes. Every 1-2 months or after consumption of approx. 500kg Enplus (A1) pellets a cleaning of the flue gas chamber and the pipe heat exchanger is required. The devices are designed and tested so that they can be installed in homes and have the necessary approvals. For the combustion air is needed. For this reason, the combined use of kitchen exhaust systems, and the ventilation in the same room with a stove is not allowed.



1.6 Warning signs

| WARNING SIGNS | |
|--|--|
|  | <p>RISK OF ELECTRIC SHOCK.</p> <p>Working in areas marked with this symbol must be done by a qualified electrician.</p> |
|  | <p>WARNING!</p> <p>Warning for hazardous locations and actions. Failure to follow can result by fatal injuries.</p> |
|  | <p>CHOKING HAZARD DUE TO CARBON MONOXIDE</p> |
|  | <p>CAUTION!</p> <p>Risk of injury. Work on locations marked with this symbol can cause injuries.</p> |
|  | <p>CAUTION!</p> <p>Hot surfaces. Work on locations marked with this symbol can lead to burns.</p> |
|  Flammable materials | <p>CAUTION!</p> <p>Risk of flammability. Work on locations marked with this symbol may cause ignition injuries.</p> |
|  | <p>CAUTION!</p> <p>Risk of frost. Work on the locations marked with this symbol may result in freezing.</p> |
|  | <p>Instructions for proper disposal of waste.</p> |
|  | <p>NO ACCESS</p> <p>Access to the boiler room to unauthorized persons, especially children should be disabled .</p> |
|  | <p>Obligatory use of protective gloves</p> |

1.7 Other warnings

| | |
|---|---|
|  | <p>WARNING</p> <hr/> |
| | <p>Never touch hot surfaces!</p> |
| | <p>The hot parts of the stove, flue gas pipes and heating pipes can cause severe burns!</p> |
| | <p><i>Use gloves when working with the stove.</i></p> <p><i>Maintain the stove only according to the instructions.</i></p> <p><i>Insulate the flue pipes and avoid possible contact</i></p> |

| | |
|---|---|
|  | <p>WARNING</p> <hr/> |
| | <p>Do not open the door for ash cleaning during operation!</p> |
| | <p>Opening the door on the stove during work can cause the switch off of the stove, injury, damage and leakage of flue gases.</p> |
| | <p><i>Open the door only during regular cleaning and maintenance.</i></p> |

| | |
|--|--|
|   | <p>WARNING</p> <hr/> |
| | <p>NEVER SWITCH OFF THE STOVE FROM ELECTRIC NETWORK DURING WORK!</p> |
| | <p>Connection to the power should be with a permanent connection to avoid the possibility of the accidental shutdown.</p> |
| | <p><i>Although the stove is secured with several levels of protection, forced power shutdown can cause unplanned failures.</i></p> |

1.7.1 System overheating

If the heating system overheats despite all the elements, it is necessary to proceed as follows.



- Do not open doors on the stove
- Turn off the boiler pressing the button  for 3 seconds
- Open all heating circuits and switch on all pumps (stove control does this automatically)
- Leave the pellet stove room and close the door
- Open all available valves on the radiators / distribution boxes

If the temperature in the system is not decreasing, call the authorized service center.

1.7.2 Smoke

Flue gases can cause poisoning!



- Do not open doors on the stove
- Turn off the stove pressing the button  for 3 seconds
- Ventilate the room where the stove is located
- Leave the room and close the door

1.7.3 Fire in the room

In case of fire in the room:



- Turn off the boiler pressing the button  for 3 seconds
- In case of fire use only extinguishers type AB with powder.

2 GENERAL OVERVIEW



The Interio pellet stove is intended for domestic use only and only for pellets with a diameter of 6mm. The stove is compact and requires only 1m² for installation, so it can be installed in the smallest space. The 30kg capacity pellet store, a weekday digital controller, a cast iron pot, an expansion vessel and safety valve make it easy to install and use the stove for central heating use. The stove is delivered with the accompanying material:

- Power cable
- Key
- Manual
- Guarantee

Additional equipment which can be used (is not supplied with an oven):

2.1 GSM modem

By using the cell phone and by sending an appropriate SMS message, you can perform the following functions:



- Set default phone numbers
- Set up the communication languages between the modem and the phone
- Turn on the boiler / stove
- Switch off the boiler /stove
- Change the default temperature
- Change work power
- Reading the status of the boiler / fireplace

2.2 Wi-Fi module

Designed for communication and control of boiler operation via the Internet. Compatible with Android, IOS and Windows devices. The user can have full control over the boiler via the application:



- enable / disable,
- change the power of work,
- change the temperature and
- to program delayed ignition and shutdown times.

2.3 Technical data

| | | |
|-----------|------|------|
| L | [mm] | 623 |
| L1 | [mm] | 657 |
| L2 | [mm] | 673 |
| B | [mm] | 634 |
| B1 | [mm] | 281 |
| B2 | [mm] | 98 |
| B3 | [mm] | 93 |
| H | [mm] | 1089 |
| H1 | [mm] | 960 |
| H2 | [mm] | 315 |
| H3 | [mm] | 151 |

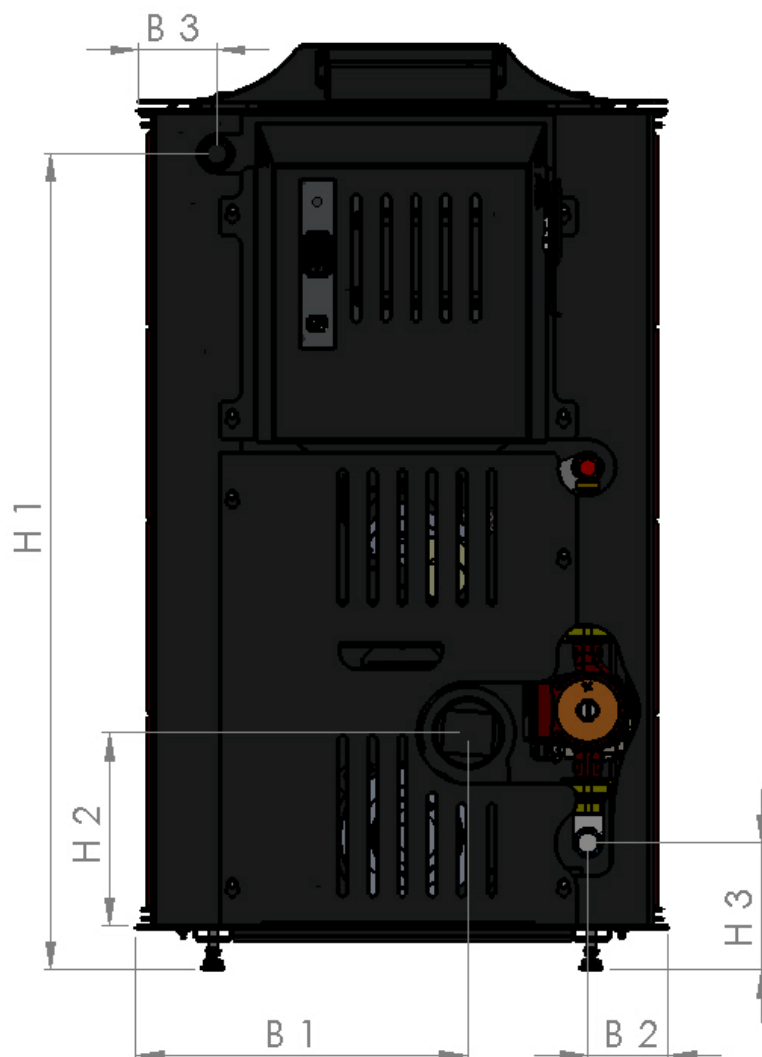

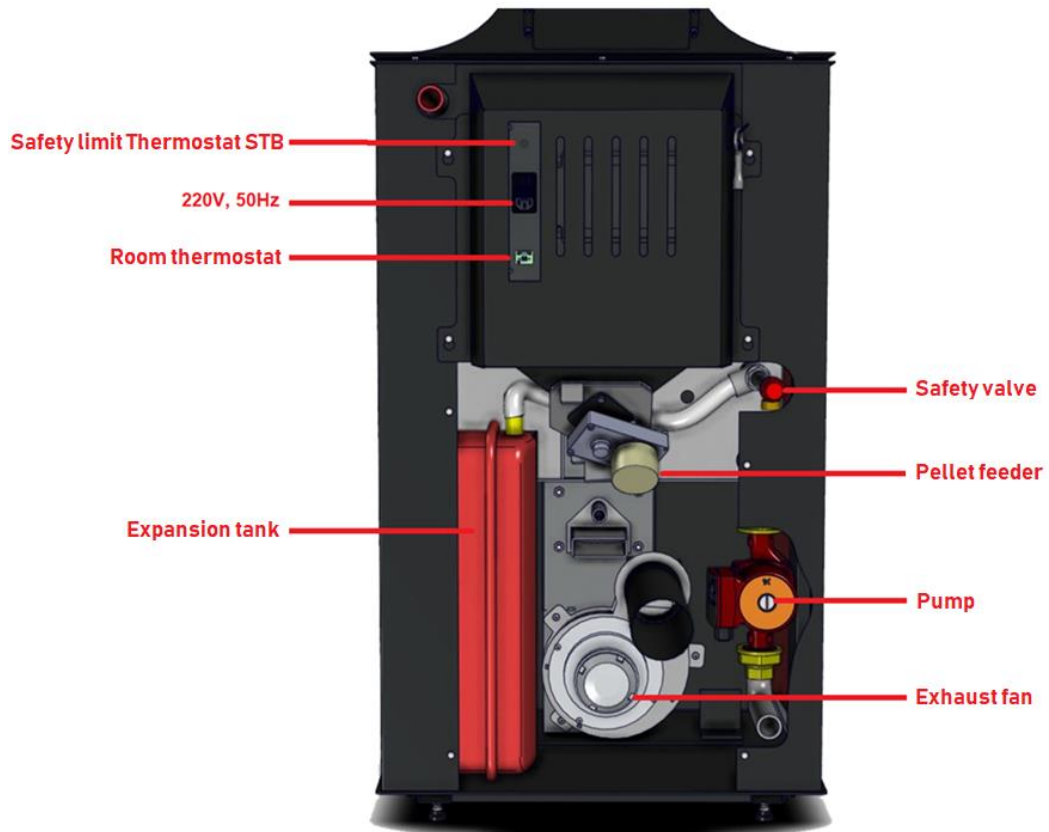
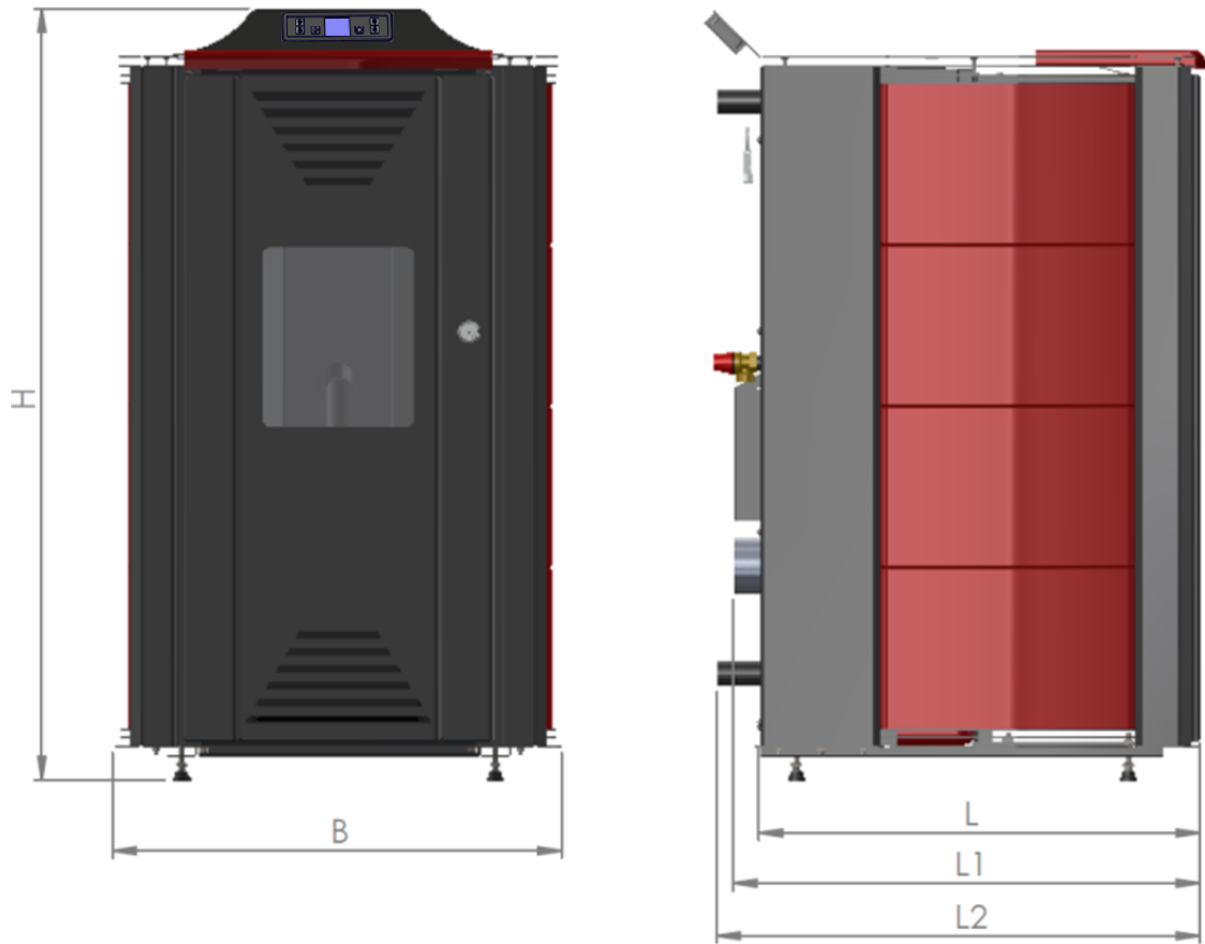

| RB | | J.M | Interio 14 | Interio 20 | Interio 25 |
|----|-----------------------------------|------|-----------------|-----------------|-----------------|
| 1 | Weight | kg. | 204 | 214 | 232 |
| 2 | Power range | kW | 4-14,1 | 6-18 | 8-25 |
| 3 | Heat transfer to the water | kW | 12,1 | 15,8 | 20,8 |
| 4 | Heat in room | kW | 2 | 2,2 | 4,2 |
| 5 | Water content | L | 33 | 25 | 37 |
| 6 | Recom. draught ratio | Pa | 5-12 | 5-12 | 5-12 |
| 7 | Water conction Inlet/Outlet | inch | 1" | 1" | 1" |
| 8 | Flue gas temperature | °C | cca160 | cca160 | cca160 |
| 9 | Max working temperature | °C | 80 | 80 | 80 |
| 10 | Max working pressure | bar | 2,5 | 2,5 | 2,5 |
| 11 | Height to center of flue pipe | mm | 315 | 315 | 247 |
| 12 | Depth | mm | 657 | 657 | 704 |
| 13 | Width | mm | 634 | 634 | 634 |
| 14 | Height | mm | 1089 | 1089 | 1000 |
| 15 | Avaliable colors | | red/beige/white | red/beige/white | red/beige/white |
| 16 | Flue pipe diameter | mm | 80 | 80 | 80 |
| 17 | Outlet / Inlet height | mm | 960/151 | 960/151 | 935/63 |
| 18 | Pellet storage cappacity | kg | 30 | 30 | 20 |
| 19 | Electrica consumption nominal/max | W | 90/340 | 100/350 | 100/350 |
| 20 | Min/max water temperature | °C | 55/80 | 55/80 | 55/80 |
| 21 | Glass dimensions | mm | 318x236x4 | 318x236x4 | 401x236x4 |
| 22 | Min/max pellet consumption | kg/h | 1-2,9 | 1,35-3,9 | 1,6-4,3 |
| 23 | Fuel | - | Pellet | Pellet | Pellet |
| 24 | Flue pipe direction | | back | back | back |

3 SAFETY INSTRUCTIONS

3.1 Proper use

3.1.1 Basic principles

The Interio pellet stove has been designed and tested in accordance with the safety regulations deriving from the EN 14785 directive (and agreed standards). However, improper use of the stove can ultimately result in the death of users and/or third parties as well as damages to the stove itself or other property.

3.1.2 Handling with the stove

The stove can only be used when it is in proper condition. Use the stove in the manner described in this manual. Get acquainted with security measures and possible dangers. Remove all faults and malfunctions that could affect your safety.

3.1.3 Use of the stove

The stove is intended for combustion of wood pellets. Any other use is improper. The manufacturer will not be held responsible for any damage caused by improper handling. Proper use implies maintenance of the installed stove, operation and maintenance conditions prescribed by the manufacturer.

The user can enter or change only those values that are specified in this manual. Any other parameter value will affect the control program and boiler operation itself, which can ultimately lead to a Failure of the system or improper operation.

3.1.4 Changes on the stove

It is forbidden to make any changes to the stove and to the equipment supplied with it. It is forbidden to deactivate the security functions. The manufacturer will not give any warranty if the user or a third party performs unauthorized intervention on the stove and equipment that comes with it.

The stove may only be used for the purpose for which it is produced. The manufacturer does not accept any responsibility for damage caused to persons, animals or property resulting from faults in installation, incorrect regulation and maintenance, and improper use of the boiler.

3.2 Pellets that can be used in boilers

The boiler is designed exclusively for burning wood pellets with a diameter of 6 mm and a length of 10-30 mm.

3.2.1 What is pellet



Pellet is obtained from wood, if it is possible, from the core of the trunk with the lowest proportion of bark. The bark contains the most moisture, dust and impurities that wood gets during growth, therefore has a lower caloric value than the core, and another problem is that it leaves the sediment when burning. Ideal wood for pellet production is one that does not burn too long or too short and creates a long-lasting glow. Pellets are made from

sawdust waste (typically in a ratio of 20-40% softwood + 60-80% hardwood), in special machine under high pressure which leads to thickening. It is not allowed to use any additives or glue during the pellet. production The pellet contains a minimal amount of moisture and ash, and has a maximum energy value for the type of wood from which they are produced.

3.2.2 Recommended wood pellets and standars

Pellets quality arises from Standard pellets C1 to EN 303-5: 2012 Table 7; Water content less than 12% according to DIN 51731 - HP 5, DINplus certification program and ÖNORM M 7135 - HP 1 or EN PLUS - UNI EN 14961 - 2 (UNI EN ISO 17225-2) class A1 or A2, 6 mm diameter, length 10-30 mm.

Particular attention should be paid to the quality of wood pellets. Low-grade pellets can cause malfunction of the stove.

3.2.3 Unallowed fuels

The pellets not consisting the standards mentioned in this manual is not allowed to burn in a stove. Using a bad quality pellet or any other material can lead to damaging your stoves's important functions and may result in the termination of the warranty and associated liability.

3.3 Obligatory information

All persons managing the stove must read the manual before starting to use it and in particular the "Safety instructions".

This applies especially to persons who occasionally work on a stove, e.g. cleaning and maintaining stoves.

This instruction should always be kept near the installed stove.

Children aged 8 and over, persons with reduced physical, motor or mental capacity, persons with insufficient experience and training, may use a device of this kind if they have been provided with supervision or have been given instructions regarding the safe use of the device and have been presented the dangers arising from it. Children should not play with such devices. The devices must not be cleaned or maintained by children without proper supervision.

3.4 Local standards

All local laws must be respected during installation, as well as standards and norms that are in force in the country where the stove is installed even though it is not listed in this manual.

During the first installation of the stove or in the event of changes on central heating system, it is necessary to inform the competent authority in charge for control, and provide all the necessary permits.

3.5 Safety instructions for the heating room

The heating room must be made according to current regulations, especially regarding fire protection. Storage of flammable materials, cleaning agents and similar materials must not be stored in the boiler room

The room where the stove is installed must be frost-resistant.

The stove should not be exposed to colds or freezing temperatures. Extreme low temperatures can cause malfunction and unexpected behavior of electronic components.

3.6 Fresh air supply

For combustion of pellets and normal work the stove needs fresh air. The room in which the stove is installed must have an opening for fresh air supply. The recommended minimum dimension is 30x15 cm.

3.7 Boiler safety devices

The pellet stove is equipped with safety systems which, in the case of unforeseen situations, serve to stop the power supply and thus stop the boiler operation.

Microprocessor control: Intervenes directly, turns off the stove until it cools down and shows an error on the display screen in case of a failure of exhaust fan, malfunction of the dispenser engine, or failure of the ignition.

Fuse: Quick fuse, protects the stove from large current drops and short circuit inside the boiler.

Safety limit Thermostat STB: Intervenes with an interruption (turn off) off the circuit of the auger (pellet feeder) and on the display is displayed **AL6**.

Vacuum gauge: Intervenes if there is insufficient pressure in the pellet stove (open door of the stove, clogged chimney) and disconnects the circuit from the auger (feeder) motor.

4 Installation

The commissioning of the system must be carried out by the authorized personnel by ThermoFLUX d.o.o. or the importer.

The Warranty will not be valid if the stove has not been commissioned by an authorized repairer.

The first start-up includes the basic operation and maintenance of the stove. The service technician authorized for the first commissioning must check the functioning of the stove at least during one complete work cycle. In some countries, it is obligatory for first commissioning to be controlled and authorized by chimney sweep or a person authorized to control.



Risk of material and physical damage due to improper commissioning. If the first start-up is done by an unprofessional person, damage to the boiler and the heating system may occur.

4.1 Installation conditions

The minimum distance from the stove must be observed.

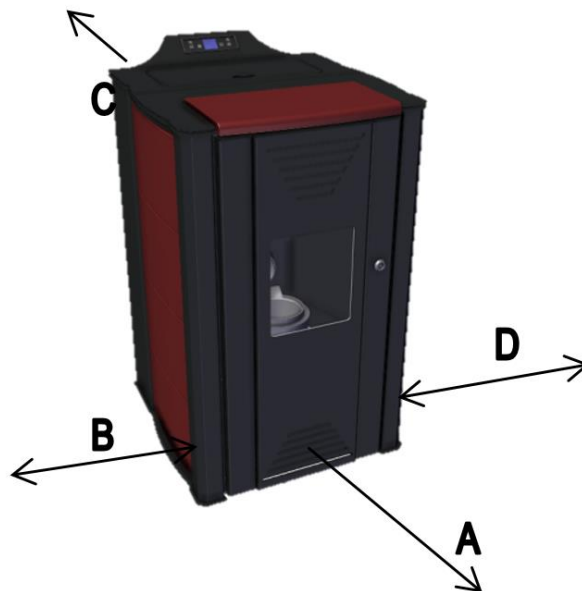

- A – Minimum distance in front of the door - 100 cm**
- B – Minimum distance from the left side - 20 cm**
- C – Minimum distance behind the chimney - 20 cm**
- D – Minimum distance from the right side - 20 cm**

4.1.1 Switch off main power supply

Be sure to turn off the main power before any work.

4.1.2 Check mechanical connections

- **Check that all components are properly connected.**
- **Check that all mechanical components are securely attached.**

4.1.3 Check hydraulic connections

- **Check that the circulation pump and the mixing valve are properly connected.**
- **Check that the safety equipment is properly connected.**
- **After completing the work, fill the system and wait an hour to control all the connections.**

The pellet stove comes with a built-in expansion tank and can only be connected to a closed heating system.

4.2 Chimney and flue gas pipes

The chimney should be calculated and constructed in accordance with the EN 13384-1 standard.

The venting of flue gas must be done in accordance with all applicable laws including those related to dimensions of the chimney and materials used for its production. Flue gas channel should be made of adequate materials, such as steel tubes, with various sealing.

In any case, materials that could potentially catch fire, e.g. wooden planks, beams, cloth, should be adequately protected with non-combustible material. For the sake of parity of dimensions, chimneys that are round in shape of the inner part should have an advantage over the rectangular-shaped chimneys.

Too small inner zone can cause irregular flow from the stove to the top which could lead to poor stove performance and excessive exhaust gas production that discharges the exhaust gas to the environment. Gas flue pipe should be permanently installed and it would be good to make safety door which would enable the cleaning of inner parts, especially the horizontal parts.

Smoke pipe should be installed fixed. It would be good to leave safety gates that could do the interior cleaning, especially in their horizontal parts.

You should avoid as much as possible horizontal mounting parts. Horizontal parts must have a slope of at least 3% upwards.

Length of the chimney pipes should be minimal and in any case not more than 3 meters.

ALL PARTS OF THE FLUE GAS PIPE NEED TO BE SECURED AND REPLACEABLE IN ORDER FOR INTERNAL CLEANING. AVOID MULTIPLE HORIZONTAL DEVIATION AND ANGLES.

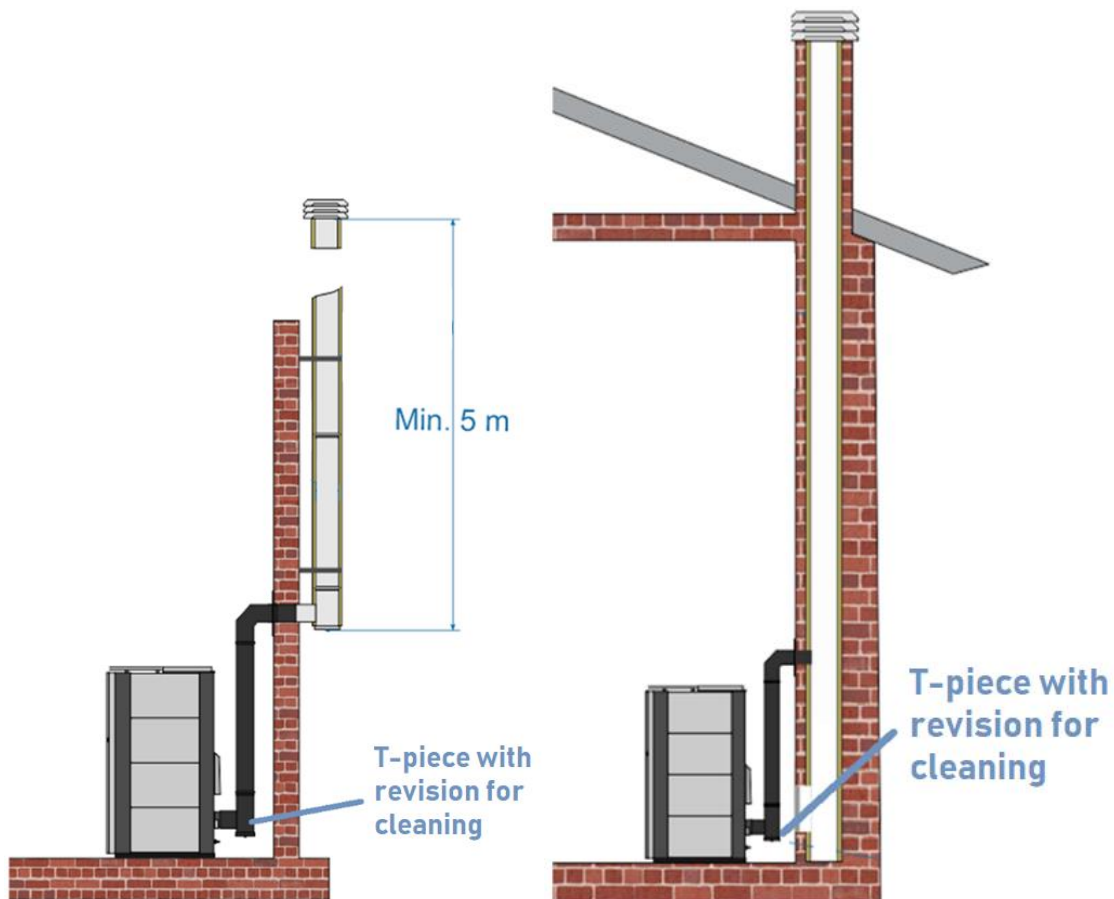

The internal cross-section of the exhaust pipes should be smooth and all connections must be hermetically sealed. Avoid as much horizontal mounting as possible. Horizontal parts should have a slope of at least 3% upwards. The length of the horizontal part of the saddle shall be minimum and in any case not more than 2 meters with the possibility of cleaning and removing the accumulated ash.

The connection to the chimney should be made with a maximum of two exhaust pipes. For stove operation, a constant negative pressure is required. At reduced power, the flue gas temperature is low and condensation may occur. It is therefore important that the chimney is well insulated.

The flue pipes should be made of non-combustible materials that are suitable and resistant to combustion products and their possible condensation. In any case, the parts or zones that are flammable, must be properly protected, such as wooden boards or beams.



FOR SMOKE PIPES, DO NOT USE METAL-FLEXIBLE CABLES. ALL PARTS OF THE SMOKE PIPE SHOULD BE SAFE AND REMOVABLE TO CLEAN CLEANING. AVOID HORIZONTAL DEVIATIONS.

If the chimney has a too high underpressure (over 20 Pa), the regulation can be achieved in different ways. One way is to easily open the cleaning door. We recommend to install the draft regulator.



The pellet stove can not be connected:

- To the chimney or the flue pipe to which another heat source is connected (gas boiler, pellet boiler, etc.)
- Ventilation system

When connecting the pellet stove to the chimney, smoke pipes with a diameter of 80mm and temperature-resistant gaskets must be used. It is recommended to install a T-piece with revision or a knee after the chimney outlet, and a piece of flue pipe of a length of min. 0.5m and then connect the stove to the chimney. It is not recommended to connect directly between the stove and the chimney without flue pipes. It is also not recommended to attach a connection of the flue pipes on the left or right, which means you do not make knee in the flue pipes in the sides.

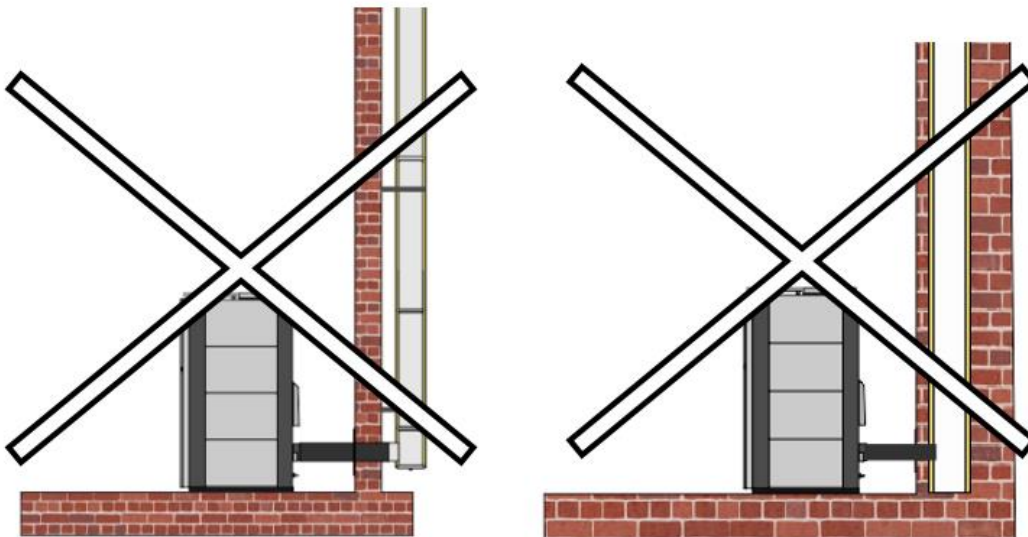

5 Connection

5.1 Hydraulic schemes for connection

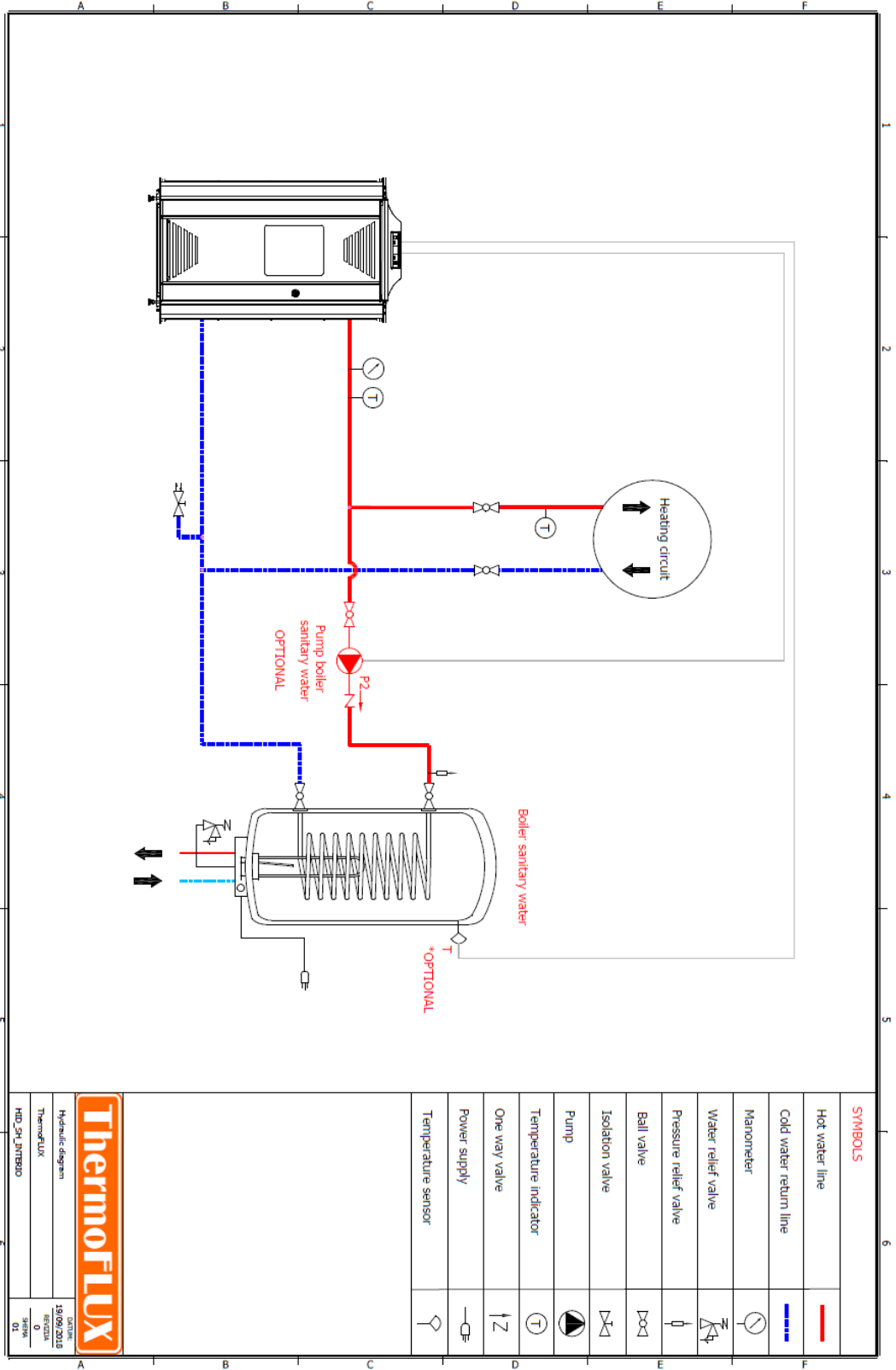

5.2 Electrical wiring diagram

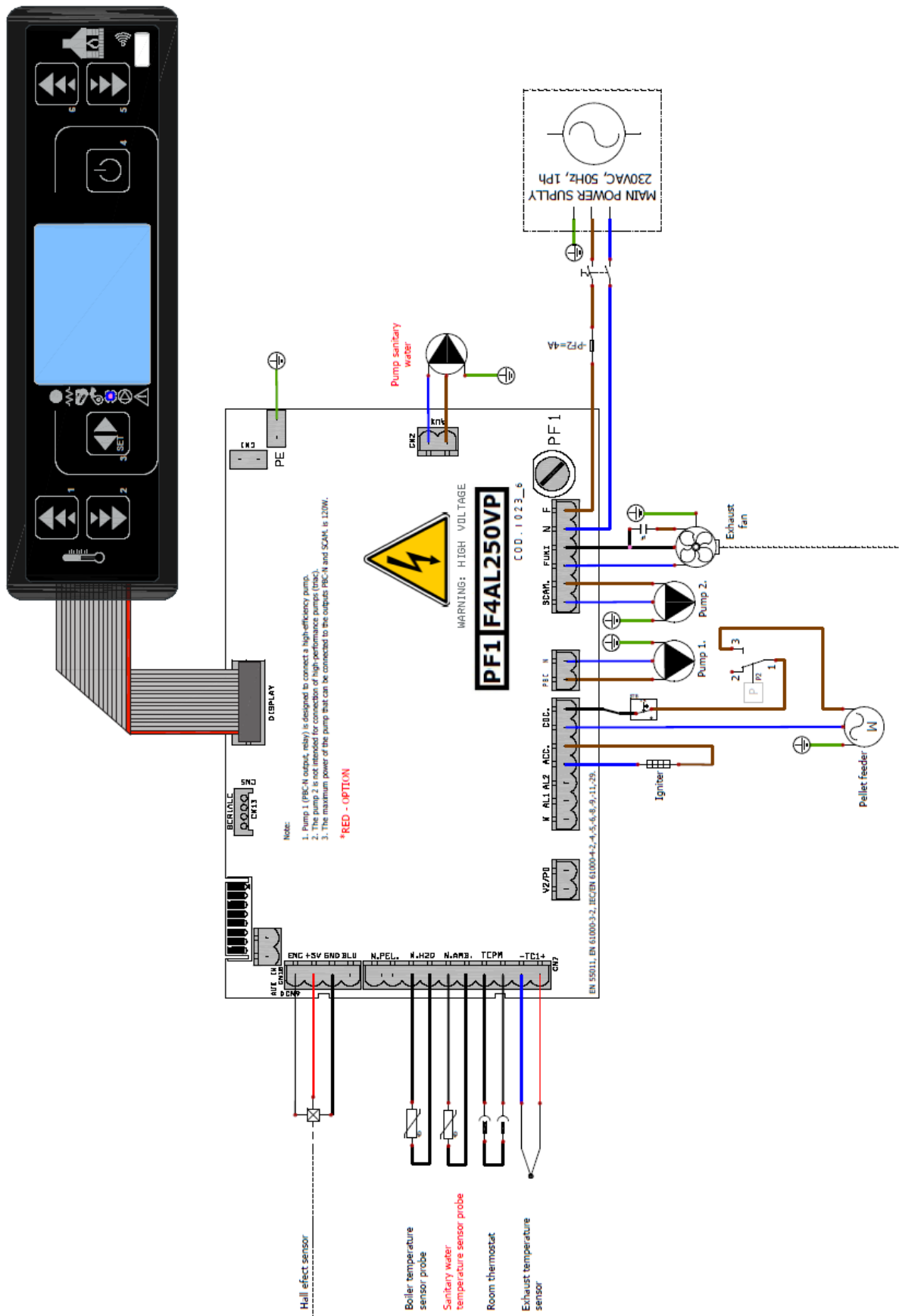

The pellet stove is supplied with built-in circulation pump, expansion vessel and safety valve. On the back of the stove is the connection for: power supply 230VAC, 50Hz with main switch, fuse and room thermostat.

5.2.1 Power supply

The stove needs to be connected to a 220V, 50Hz via a separate fuse 6-10A (FAST).

5.2.2 Room thermostat

The user has the possibility to place the room thermostat in one room and does not need to be in the same room where the pellet stove is. Operation of the stove with an external thermostat connected to the room thermostat connection may differ if we have activated the **STAND BY** function. The connection for the room thermostat comes from the factory with a bridged connection, which means that its contacts are closed. Only room thermostats with potential-free contacts may be connected. It is recommended that the installation and connection of the room thermostat be carried out by an authorized service technician.

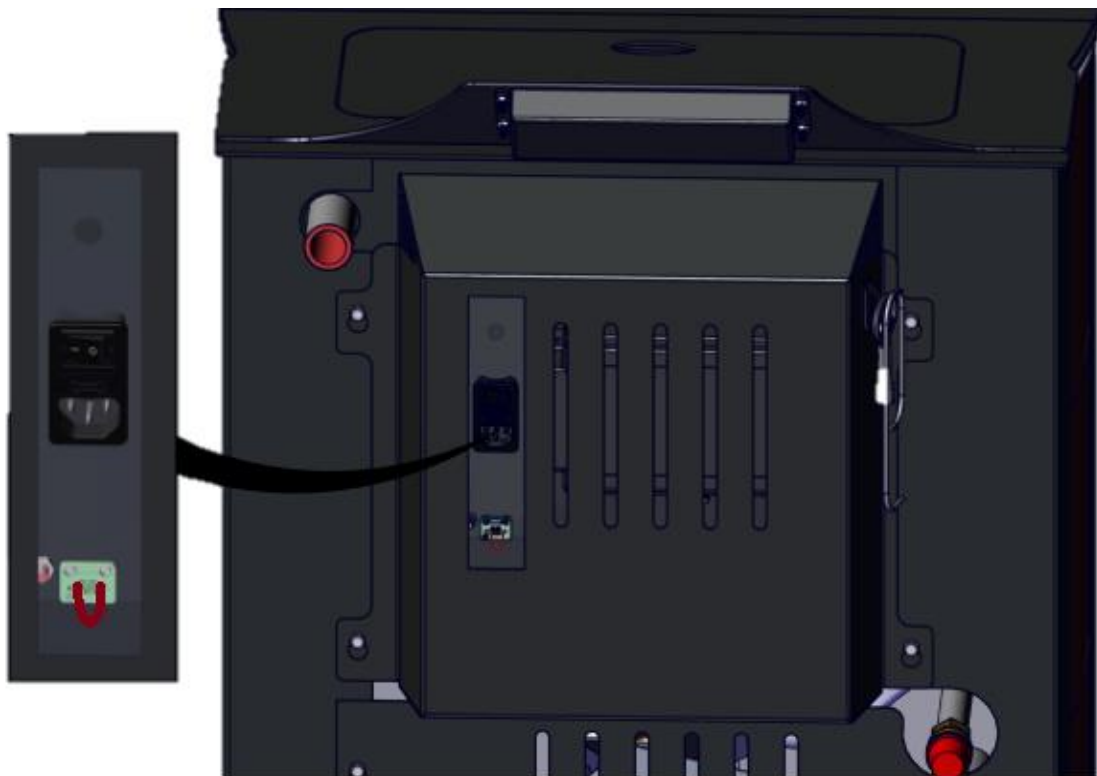

6 Function of stove

6.1 Overview of the controls and display and their basic functions

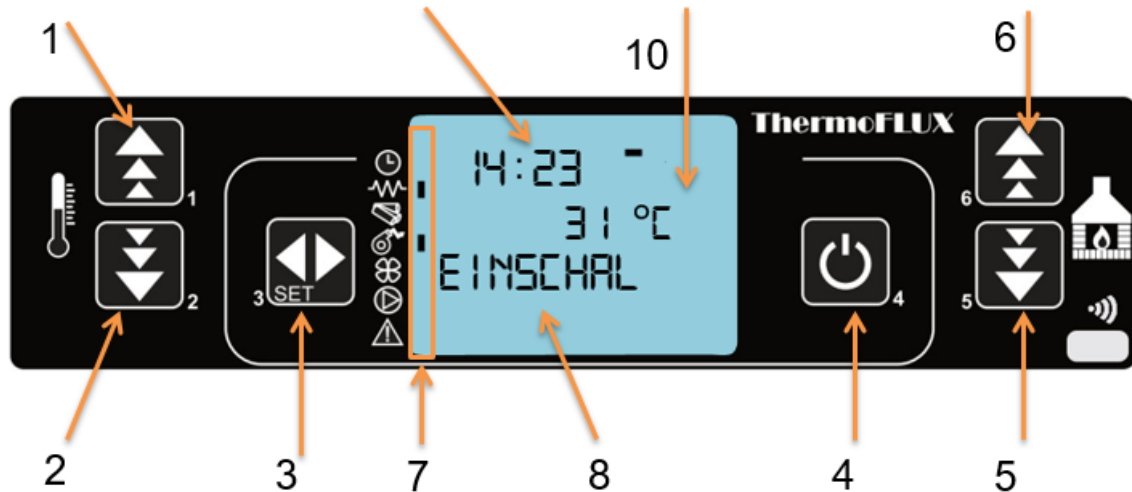

Button

Description

1 - 

Increasing temperature and program functions (adjusting days, time...)

2 - 

Decreasing temperature and program functions (adjusting days, time...)

3 - 

Changing - accepting program

4 - 

ON / OFF, program exit

5 - 







Decreasing power, navigate through the menu

6 - 

Increasing power navigate through the menu

7

When mark is visible

| | | |
|---|------------------|--|
|  | Clock | <ul style="list-style-type: none">• programmed ignit. active |
|  | Heater | <ul style="list-style-type: none">• heater active |
|  | Pellet dosage | <ul style="list-style-type: none">• auger active |
|  | Smoke fan | <ul style="list-style-type: none">• fan active |
|  | Primary air fan | <ul style="list-style-type: none">• fan active |
|  | Circulating pump | <ul style="list-style-type: none">• pump active |
|  | Alarm | <ul style="list-style-type: none">• alarm active |

Display

| | |
|-----------|-----------------------------|
| 8 | Info |
| 9 | Clock |
| 10 | Water temperature indicator |

Regulation on the stoves "Pelling" is most important electronic component. It is consisted of key controlling modul set under the cover of the stove and controlling unit with display set on the front side of the stove. With controlling unit it is possible to control functions of the stove and also to check information about present state of the stove.

Due to the possibilty to work in 5 (five) different powers, regulation can satisfy needs to increase or decrease heating by automatic adjustment of power.

If there is a need to increase power, this is registered by regulation and regulation gives a signal to increase power by adding more pellet as well as proportional increase of air flow in the burning basket.

When desired temperature is reached (need for heating energy is satisfied) regulation is decreasing power (modulates), or when room thermostat gives signal that set temperature is reached, stove then goes into SHUT DOWN mode (if mode STAND-BY is ON)

6.2 Principle of stove operation

Principle of the stove operation is very simple.

When button for start is pressed stove goes into IGNITION MODE. START is displayed, and after that PELLET IGNITION. Usually this phase lasts for 5-15 minutes depending on type of the stove and pellet quality. At that point dosing system is activated, igniter and suction fan. Dispenser is making initial dosing of pellet into burning basket. At the same point igniter starts to ignite pellet and suction fan is on and is making necessary underpressure needed for combustion. When temperature sensor for flue gasses detects that temperature in the chimney has reached necessary value, regulation then changes working mode of the stove into FLAME STABILIZATION.

This phase (FLAME STABILIZATION) lasts for 2-3 min. (depending on the type of the stove and in this phase igniter goes off. After flame stabilization, stove goes into the normal working mode and changes power from power 1 to set power. On display is written WORK. On the right side set power is displayed and in the last

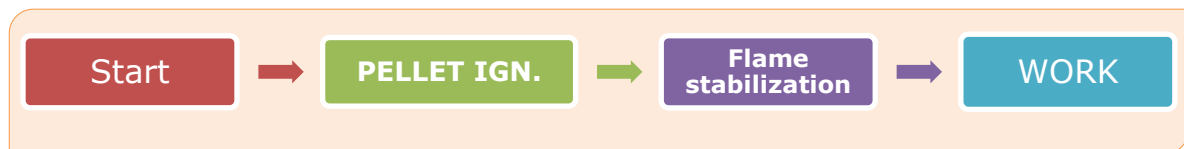

6.3 Schematic representation of the menu control

By pressing button SET we enter general menu.

| MENU | | VALUE | DESCRIPTION |
|-------------------------------|-----|---|--|
| MENU 01 SET CLOCK | SET | TABLE 1 | TIME AND DATE ADJUST |
| MENU 02 SET CHRONO | SET | M-2-1 ENABLE CHRONO | PROGRAMED SWITCHING ON - OFF |
| | | ON / OFF M-2-1-01 ENABLE CHRONO | |
| MENU 03 SELECT LANGUAGE | SET | HR-IT-EN-DE-FR-ES-PT | LANGUAGE SELECTION |
| MENU 04 MODE STAND-BY | SET | ON - OFF | ROOM THERMOSTAT MODE - SWITCH OFF BOILER (ON) , - MODULATION (OFF) |
| MENU 05 MODE BUZZER | SET | ON - OFF | BUZZER |
| MENU 06 LOAD INITIAL | SET | 90 SEC | INITIAL LOAD OF THE PELLET |
| MENU 07 STATE STOVE | SET | WATER TEMP.; EQHAUST GASES TEMP.; EQHAUST FAN RPM. | STATE OF THE BOILER |
| MENU 08 SETTINGS TEHNIC | SET | ONLY FOR TECHNICAL PERSONAL | |
| MENU 09 FUEL TYPE | SET | PELLET - WOOD | FUEL TYPE SELECTION |

BUTTONS 1 AND 2 - CHOOSE DESIRED
VALUE

BUTTONS 5 AND 6 - CROSSING
BETWEEN MENUS

BUTTON 3 (SET) - ACCEPT
BUTTON 4 (ON/OFF) - BACK

| | | | |
|-------------------------|-----------------------------------|-----------|-------------------|
| MENU 01 SET CLOCK | MENU 01 MONDAY DAY 08: | PON - NED | DAY ADJUSTMENT |
| | MENU 01 TIME CLOCK : 33 | 00-24 | HOUR ADJUSTMENT |
| | MENU 01 MINUTES CLOCK 30 | 00-59 | MINUTE ADJUSTMENT |
| | MENU 01 DAY CLOCK 30 | 01-31 | DATE ADJUSTMENT |
| | MENU 01 MONTH CLOCK 13 | 1-12 | MONTH ADJUSTMENT |
| | MENU 01 YEAR CLOCK | 00-99 | YEAR ADJUSTMENT |

| | | | | | | | | | | |
|------------------------------|------------------------------|--|--|---|---|---|--|------|--|--|
| MENU 02 SET CHRONO | | | | | | | | | | |
| M-2-1 ENABLE CHRONO | M-2-2 PROGRAM DAY | ON/OFF M-2-2-01 CHRONO DAY | 06:00 M-2-2-02 START 1 DAY | 10:00 M-2-2-03 STOP 1 DAY | 15:00 M-2-2-04 START 2 DAY | 19:00 M-2-2-05 STOP 2 DAY | | | | |
| | M-2-3 PROGRAM WEEK | ON/OFF M-2-3-01 CHRONO WEEKLY | 06:00 M-2-3-02 START PROG-1 | 14:00 M-2-3-03 STOP PROG-1 | ON / OFF M-2-3-04 MONDAY PROG-1 | ON / OFF M-2-3-05 TUESDAY PROG-1 | ON / OFF M-2-3-06 WEDNESDA PROG-1 | | ON / OFF M-2-3-07 SUNDAY PROG-4 | |
| | M-2-4 PROGRAM WEEK-END | ON/OFF M-2-4-01 CHRONO WEEK-END | 06:00 M-2-4-02 START 1 WEEK-END | 12:00 M-2-4-03 STOP 1 WEEK-END | 16:00 M-2-4-04 START 22 WEEK-END | 22:00 M-2-4-05 STOP 2 WEEK-END | | | | |
| M-2-1-01 ENABLE CHRONO | | | | | | | | | | |

BUTTONS 1 AND 2 - CHOOSE DESIRED VALUE

BUTTONS 5 AND 6 - CROSSING BETWEEN MENUS

**PROGRAM WEEK (M-2-3)
POSSIBILITY OF 4 (four) TIMES FOR SWITCHING ON OR OFF**

6.3.1 Clock adjustments

Clock adjustments can be done on following way:

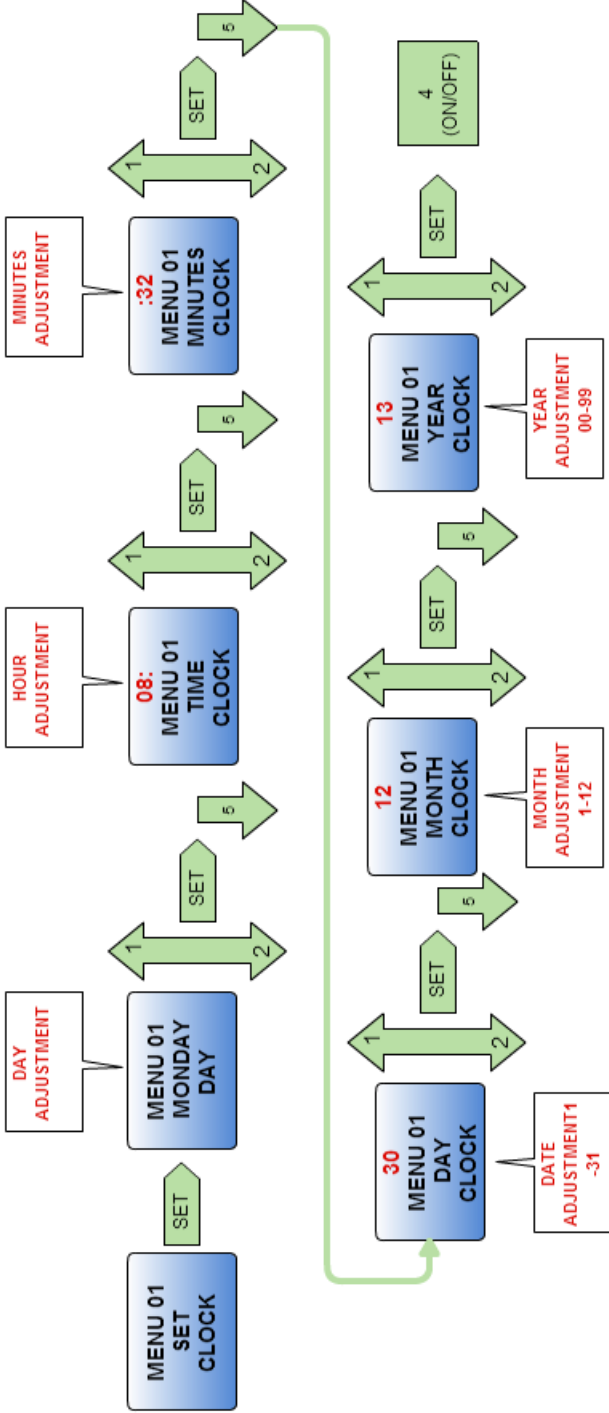

6.3.2 Adjustments of the programmed on and off mode

6.3.3 Stove has possibility for programmed on and off mode during a day and this option is regulated on three ways:

1. **DAY PROGRAM**, in this mode we can set 2 (two) different times for ignition and shutting down of the stove. This applies to all days in the week. (Scheme 2)
2. **WEEK PROGRAM**, in this mode we can set 4 (four) different times for ignition and shutting down. In this mode, we can choose day in the week (MON-SUN) in which we want stove to work for each program (Scheme 3)
3. **SUN-SAT PROGRAM**, in this mode we can set 2 (two) different times for ignition and shutting down, but only for SATURDAY and SUNDAY. (Scheme 4)

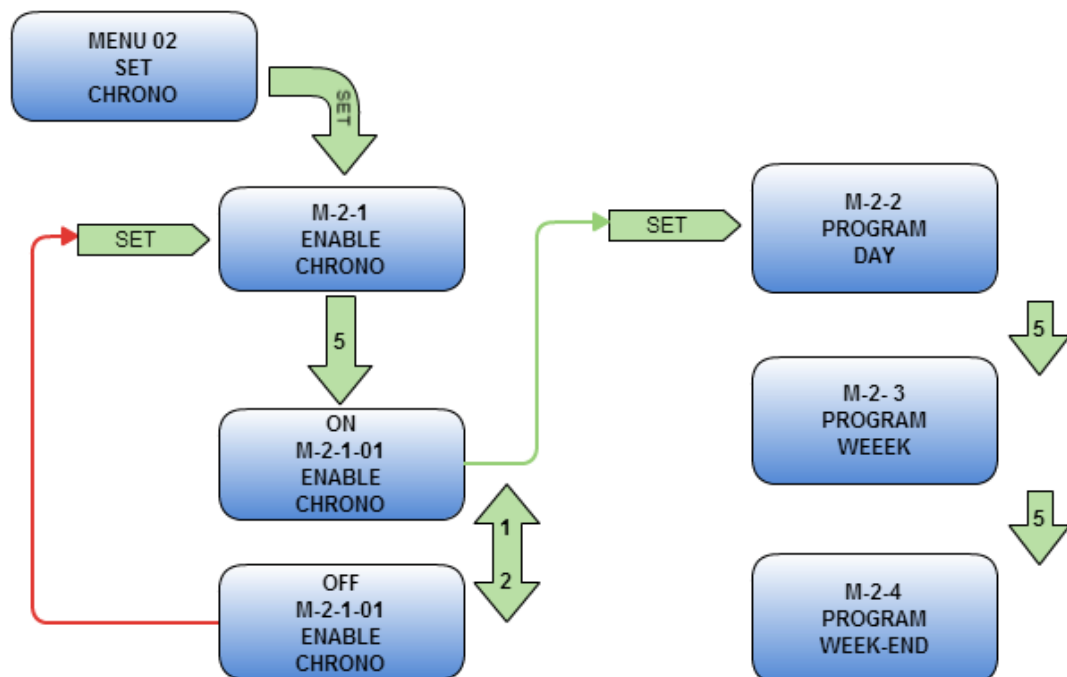

Scheme 1.

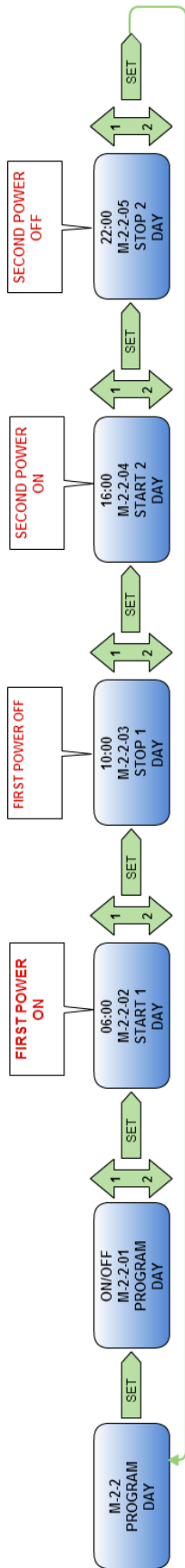

Scheme 2.

TIMES FOR FIRST AND SECOND POWER ON SHOULD NOT OVERLAP

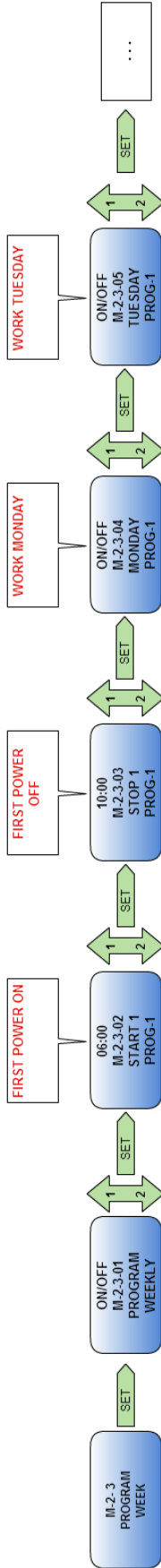

Scheme 3.

PROGRAM WEEK HAVE POSSIBILITY 4 (FOUR) TIMES FOR POWER ON/OFF.
NAKON ŠTO ZADAMO ŽELJENO VRIJEME , BIRAIMO DANE U KOJIMA ŽELIMO DA TAJ PROGRAM RADI

TIMES FOR POWER ON SHOULD NOT OVERLAP

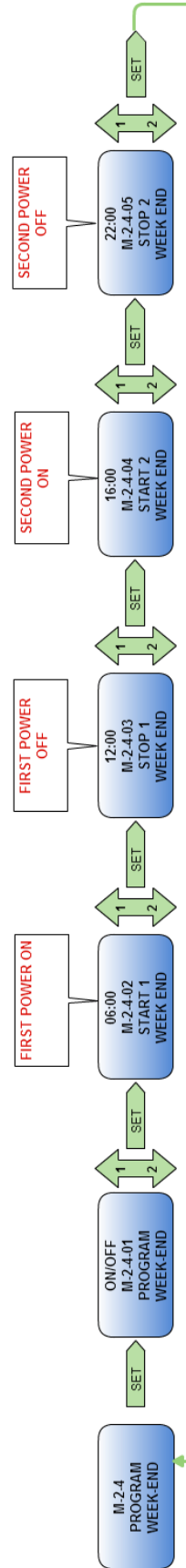

Scheme 4.

TIMES FOR FIRST AND SECOND POWER ON SHOULD NOT OVERLAP

6.3.4 LANGUAGE OPTIONS

Language settings are adjusted by pressing the SET button, and after that by pressing of button 5 or 6 we choose option MENU 03-LANGUAGE.

By pressing of the SET button language menu is opened (italian,english,german,french, croatian...) in which we can choose desired language by pressing button 1 or 2.

When desired language is chosen, confirmation is to be done by pressing button SET.

Returning back is done by pressing button 4 (ON/OFF)

6.3.5 STAND BY mode

STAND BY is used in two ways..

- In the case that stove shuts down because desired temperature is reached (set ON) ,
- In the case that stove modulates when desired temperature is reached (set OFF).

Function STAND BY can be set ON or OFF on following way:

STAND BY mode is activated by pressing button SET, and afterwards by pressing buttons 5 and 6 we choose desired item in the MENU 04 – STAND BY MODE.

By pressing SET we are opening options ON or OF (chosen by pressing of buttons 1 or 2, and confirmed by pressing of button SET).

6.3.5.1 *STAND BY mode with installed sensor for water temperature*



Connection for room thermostat is delivered overbridged, which means that contact is closed.

1. FUNCTION STAND-BY SET ON

In the case that function STAND-BY is activated (ON), stove will shut down when desired temperature is reached and above by 2 degrees C, and after 2 minutes of time pause (set in factory) TON-WAITING COOLING is displayed. If temperature do not decrease below set temperature during 4 (four) minutes, on display is written TON-REQUEST WAITING.

When temperature of the water in stove is below set temperature by 2 degrees C, stove will start again with ignition mode and it will work on set power.

2. FUNCTION STAND-BY SET OFF

In the case that function STAND BY is not activated (OFF) , and that connection for the room thermostat is not overbridged, stove will always work in power 1 no matter which power is set.

In the case that function STAND BY is not activated (OFF), and connection for room thermostat is overbridged (set in the factory) stove will work in the power chosen by the user, and when desired temperature is reached will go into modulation mode. Stove will shut down only if the temperature in the stove is 80 degrees C, and will start again when temperature drops down below desired temperature.

6.3.5.2 STAND BY mode with room thermostat connected

1. FUNCTION STAND-BY SET ON – room thermostat shuts down stove

When room thermostat sends signal that desired temperature in the room is reached (contact is open/temperature is reached) stove will shut down after 2 minute (factory settings- in the case that temperature in the room changes all to prevent constant turning on and off of the stove) on display is written **tOFF-WAITING REQUEST**.

When room thermostat gives signal that room temperature is low (contact closed/ temperature needs to be reached) stove will start ignition and on display is written **tON**.

Remark: Stove functioning primarily depends on temperature of the water inside of stove and factory settings inserted. If stove is in state of **WAITING COOLING** (water temperature is reached), eventual request of the thermometer will be ignored.

2. FUNCTION STAND-BY SET OFF – room thermostat gives signal to the stove to work in POWER 1

In the case that function STAND BY is not activated (OFF) stove will work in power chosen by the user and when desired temperature is reached stove will modulate (will not shut down but working power will change to lowest).

Stove will shut down only if temperature of the water in the system is 80 degrees C, and on display is written **WAITING COOLING**. Stove will start again when temperature in the system drops down below set temperature.

6.3.6 Option Buzzer

BUZZER is used in the case that user want to hear sound signal from the stove in the case of activated alarm (set ON), or without sound signal (set OFF).

Option BUZZER is activated by pressing of button SET, and after that with buttons 5 or 6 we choose item **MENU 05- OPTION BUZZER**.

By pressing of the button **SET** choice **ON** or **OFF** is opened (with buttons **1** or **2** we are selecting option and confirmation is done by pressing **SET**).

6.3.7 Filling of spiral dispenser

Filling of spiral dispenser with pellet is done when pellet is loading for the first time or in the case of empty silo. Process of filling of spiral dispenser is set to 90 seconds .

Filling of spiral dispenser is done by pressing of button SET, and after by pressing buttons 5 or 6 we choose **MENU 06-FILLING OF SPIRAL**.

Filling os spiral is activated by pressing of button SET.



Prior to start up of the stove, check combustion chamber. There is a big possibility that there are some leftovers from pellet in it while spiral dispenser was filled. Combustion chamber needs to be empty and then ignition process can be initiated.

6.3.8 STATE OF THE STOVE

State of the stove is only of informational character and its purpose is to give us information about condition of the stove. On display information is randomly changed about water temperature in the stove, flue gasess temperature, fan RPM, etc.

To enter this option press SET, after that with buttons 5 or 6 we choose **MENU 07 – STATE STOVE**.

6.3.9 Technical settings

TECHNICAL SETTINGS are foreseen for authorised personnel only.

6.3.10 FUEL TYPE

FUEL TYPE is not using on the Interio stoves

7 Ignition and shutting down of stove

Ignition sequence and description of regulation

Basic function of the regulation is to secure reliable ignition of used fuel, optimal conditions for combustion and controlled sequence for shutting down. Depending on working power, and complexity of the heating system, parameters are read and controlled differently. Some of the most important ways of working are described with relevant values.

Before start up following things needs to be checked:

- Silo needs to be filled with pellet
- Silo doors needs to be closed
- Combustion chamber/basket needs to be cleaned
- Ash pot needs to be clean
- All doors on stove needs to be closed
- Stove must be connected to electric source - 220 V, 50 Hz

7.1 Ignition

Press and hold button 4  for 3 (three) seconds. Stove will start with ignition.



START will be displayed, on the left side of display we see that igniter and suction fan are activated. Mark **ton** is showing that room thermostat is connected or overbridged on connection for room thermostat (default).

After that, on display we have text **LOAD PELLETT** and on the left side we see that feeding of pellet is activ.



After ignition of pellet, and after temperature of flue gasses raise on value of 55 °C, regulation receives signal that fire is on and stove continues to work with set values.

7.2 Shutting down of stove

Press and hold button 4  for 3 (three) seconds. On display it is written **CLEANING FINAL**. Suction fan is working on maximum, feeding of pellet is stopped.

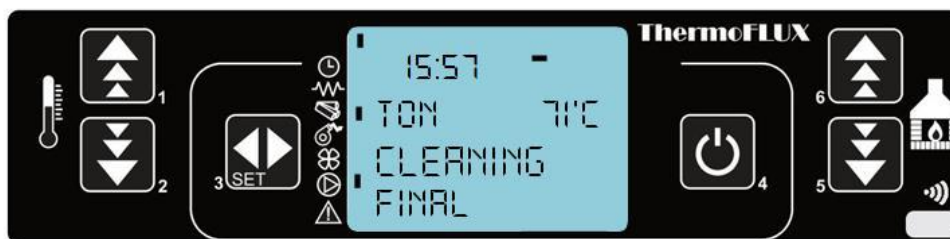

7.3 Stove power adjustments

During working phase, it is necessary to set working power in which we want stove to work.

Adjustments of the working power is possible in the range from 1-5, and selection of desired power is done by buttons 5 or 6 (*1). On upper line it is written **WORK** and set power (*2), and present working power sign is blinking on lower line on the right side (*3).

Power 1 is lowest and power 5 is highest power.

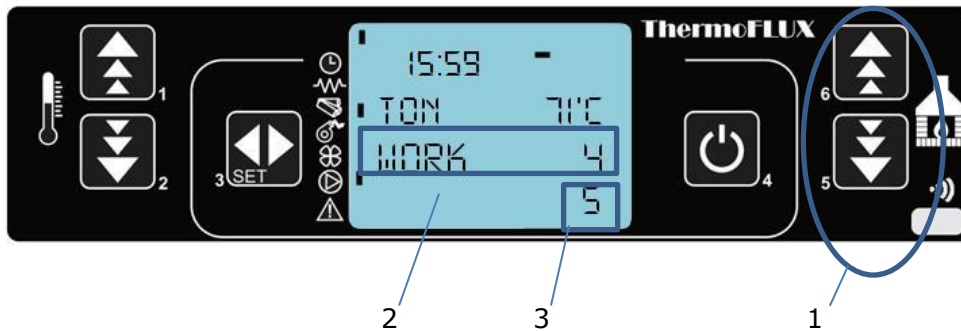

Regulation on the stove is set in the way to modulate (power goes into lowest one) it's work when 4 C is reached below set temperature – read **6.5 Modulation**

7.4 Adjustment of water temperature in stove

Adjustment of water temperature in the stove is done by pressing button 1 or 2 (*1). Temperature can be set in range from 55 °C to 80 °C (*2). These are factory settings and it is not possible to set lower or higher temperature then above mentioned.

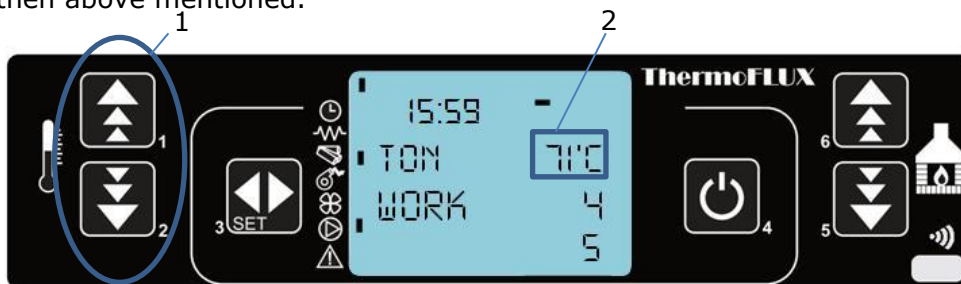

7.5 Adjustment of sanitary water temperature

Adjustment of sanitary water temperature in the boiler is done by pressing button 2 first, then set the temperature between 55°C and 80°C with the buttons 1 and 2. After selecting the desired temperature it is necessary to confirm with SET button. These are the factory settings and it is not possible to set lower or higher temperature of the sanitary water.



7.6 Modulation

When water temperature in stove is near to set value regulation begins to modulate its work and changes power to lowest. Modulation starts 4 °C below set temperature.

EXAMPLE: We have adjusted water temperature on 73°C and power 5, regulation will work in power 4 when temperature is 70°C, on 71°C stove will work in power 3, on 72°C power is 2 and when 73°C is reached then stove is working in power 1. **MODULATION** is displayed.

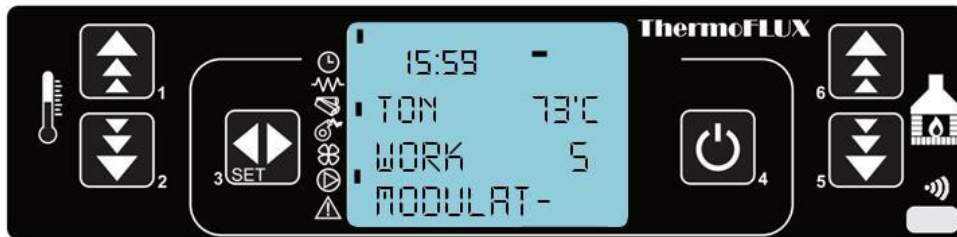

If temperature rises above set temperature by 2 °C, stove will be shut down automatically and on display will be written **WAIT COOLING**.



When temperature in the stove decreases for 2 °C below set temp. regulation will start process of ignition again.

7.7 Cleaning of FIRE-POT

During its work stove has set timer for cleaning of combustion basket (fire-pot) after certain time. This phase is shown on display and work of the stove is set to lower power, and suction fan is working on maximum for certain period of time as set in the factory.



When cleaning phase is finished, stove will continue to work and power will be set on power chosen before.

8 Cleaning and maintenance

To secure proper work of the stove, cleaning and maintenance is necessary.

Cleaning can be divided in three stages :

- **Daily**
- **Weekly**
- **Monthly**

8.1 Daily cleaning

- Turn the stove off and wait until it has been cooled.
- Open the stove door.
- Using safety gloves clean combustion deposits out of the firebox to ensure a smooth flow of air necessary for efficient combustion. Using safety gloves take the firebox out and empty its content into a fire-resistant container.
- Clean the holes in the firebox with an appropriate screwdriver (if needed) .
- Put the firebox back onto the bearing making sure it is properly seated on the heater.
- Close the door before ignition.

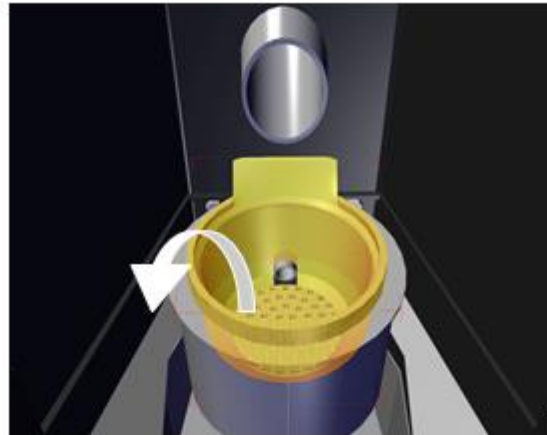

8.2 Weekly cleaning

- Turn the stove off and wait until it has been cooled.
- Open the stove door.
- Using the safety gloves take the ash pan out of the stove and empty it into a fire-resistant container.
- Put the ash pan back into the firebox.
- Close the door before ignition



8.3 Cleaning the tube heat exchanger

i We recommend cleaning of heat exchange tubes before cleaning of ash pot and braizer basket

1. Turn the stove off and wait until it has been cooled.
2. Remove the cover by easy pull up .



3. Under the cover are two plates (14 Interio has one) where there is a place where you put the lever for cleaning

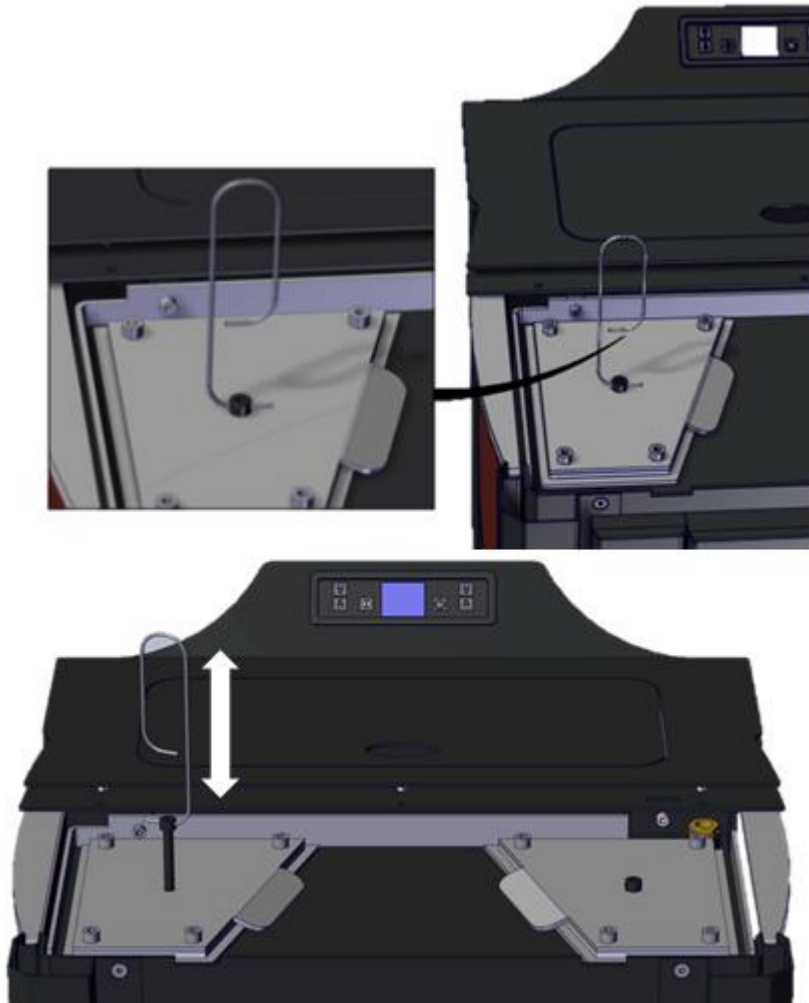

Pulling up and down, clean the tubular exchanger of the ash deposit.

4. In the interior of the firebox (behind) is the cover of the flue gas chamber fixed with butterfly screws.

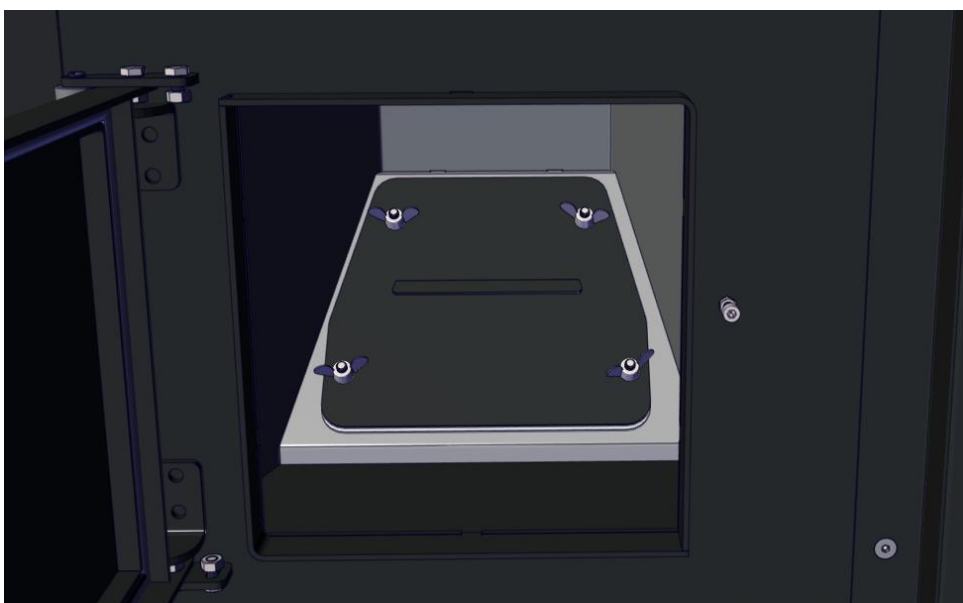

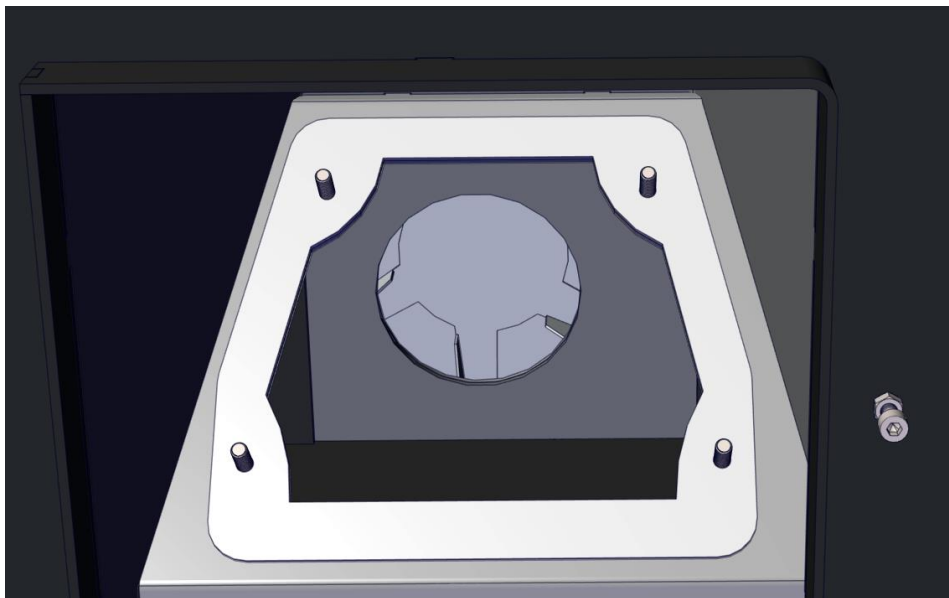

5. Remove the cover and with a vacuum cleaner remove accumulated ash, also the ash deposits from the fan blades.



6. After cleaning put all the parts back to the place where they were

9 Alarms

If faults occur in the heating system, it is possible to fix some of them by following these instructions.

| Display | Description | Solution |
|---|---|--|
|  | Alarm active- indicated next to the sign for alarm | Cancel the alarm can be executed by pressing the button 4  After that, the display lists FINAL CLEANING lasting 4 minutes. After that we can restart the boiler if we solve the problem. |
| NO IGNITION | Failed ignition. | No pellets in the silo - fill the pellets in a silo Dosage spiral empty - initial filling A foreign object stuck dosage spiral - clean Poor quality pellets (wet pellet, long pellets, dust into pellets) - change the type of pellets Pellet igniter is defective - replace it Contact Service Restart the boiler. |
| NO PELET | During operation of the boiler, flue gas temperature has decreased below the permitted values | No pellets in the silo - fill the pellets in a silo Dosage spiral empty - initial filling A foreign object stuck dosage spiral - clean Poor quality pellets (wet pellet, long pellets, dust into pellets) - change the type of pellets Call service |
| SMOKE PROBE | Flue gas temperature sensor is defective or not connected. Boiler lists alarm is active and goes off. | Call service |
| WATER PROBE | Water temperature sensor is faulty or not connected Boiler lists alarm is active and goes off. | Call service |
| HOT FUMI | Flue gas temperature is above the allowed (250 ° C). Boiler lists alarm is active and goes off. | The boiler has not been cleaned, smoke sensor is dirty. Clean boiler and restart the ignition. Excessive amounts of feed pellets. |

| | | |
|-----------------------|--|--|
| | | Call service |
| SAFETY THERMAL | Safety thermostat (STB) has been activated because the boiler water temperature exceeded 95 ° C. | <p>Wait for the boiler to cool down and then unscrew the plastic cap and suitable tool to reset the switch.</p> <p>It is possible that the pump is out of service and there is no water circulation</p> <p>Call service.</p> |
| BLACK OUT | The boiler is out of power | Reset alarm and start again |

10 Instruction about safety removal and proper disposal of stove

10.1 Disposal

Following elements are made of metal and can be disposed on landfills for metal:

- stove
- cover metal sheets
- feeding system (except motor)
- braizer basket

Electronic components can be recycled .

Glass, glass wool and plastic parts can be recycled on landfills.

Motor auger is made of few types of material which can be recycled.



Oil and capacitors can be disposed only in special waste disposal sites.

11 Guarantee

11.1 Guarantee period

Guarantee period of 5 years applies on stove body, metal covers and silo for pellet, and 2 years on electric component (regulation, motor, ignitier)

ThermoFLUX d.o.o. is responsible for service in BiH during guarantee period for failures as described in paragraph related to terms for guarantee,

Guarantee in other states is to be provided by authorised importer-distributor.

11.2 Guarantee terms

First start up of the stove needs to be done by authorised service, or person authorised by ThermoFLUX or authorised importer – distributor.

Stove must work in accordance with terms and conditions given in this manual.

Stove needs to be instaled in accordance with all state regulations and law terms.

Quality of pellet must comply with all stnadards given in this manual.

11.3 Exemption from the guarantee

Guarantee does not cover:

- Unauthorised and negligent handling and maintenance
- Unauthorised opening and servicing of the stove
- Improper installation, mechanical damage
- Damages caused by non-complying with instructions given in manual

Damages caused by other conditions such are: fire and water, high voltage, thunderstroke.

ThermoFLUX d.o.o. INTERIO 14

2,1
kW

12,0
kW

ENERGIA · ЕНЕРГИЯ · ΕΝΕΡΓΕΙΑ · ENERGIJA · ENERGY · ENERGIE · ENERGI

2015/1186

ThermoFLUX d.o.o. INTERIO 20

2,2
kW

15,7
kW

ENERGIA · ЕНЕРГИЯ · ΕΝΕΡΓΕΙΑ · ENERGIJA · ENERGY · ENERGIE · ENERGI

2015/1186

ThermoFLUX d.o.o.
Bage br.3, Jajce
Bosnia and Herzegovina
Tel/fax +387-30-657-100
www.thermoflux.ba

2018

